



# **PARTS CATALOGUE**

## **POWER PRUNER PPT-300ES(37)**

**37000001 -**

# 1. ENGINE COVER

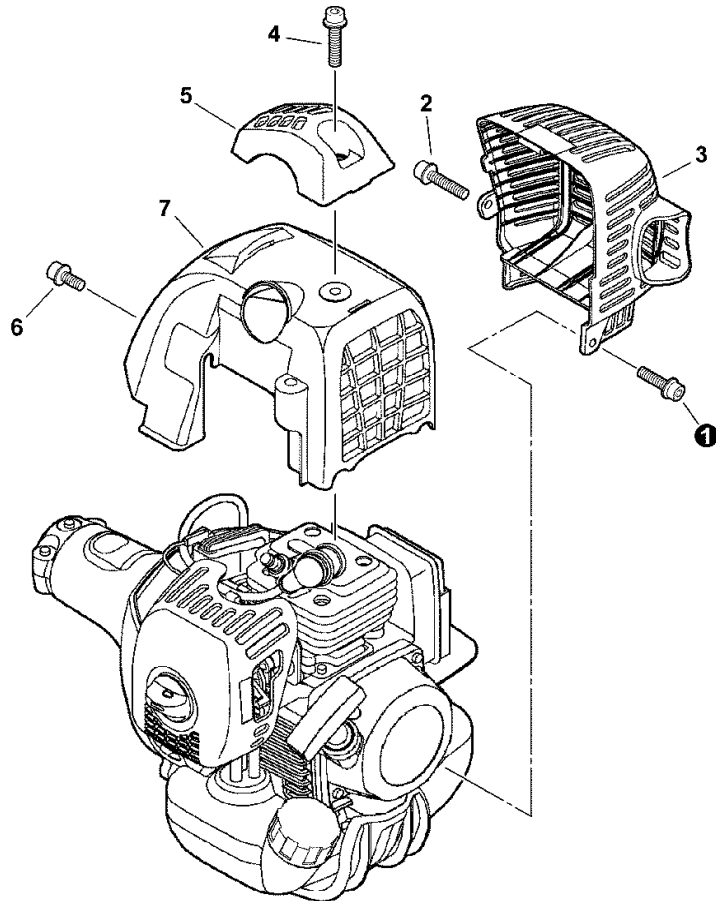

KEY	LV	PART NUMBER	Q'TY	DESCRIPTION	REMARKS	NOTE1	NOTE2
1		V203-000260	1	BOLT,5	FCB5*16		
2		900106-05020	1	BOLT,5			
3		A320-000400	1	COVER,MUFFLER			
4		V203-000270	1	BOLT,5	FCB5*20		
5		A162-000110	1	GUARD, TOP			
6		900106-05010	1	BOLT, H.S. 5*10			
7		A160-000800	1	COVER,CYLINDER			

## 2. FUEL TANK

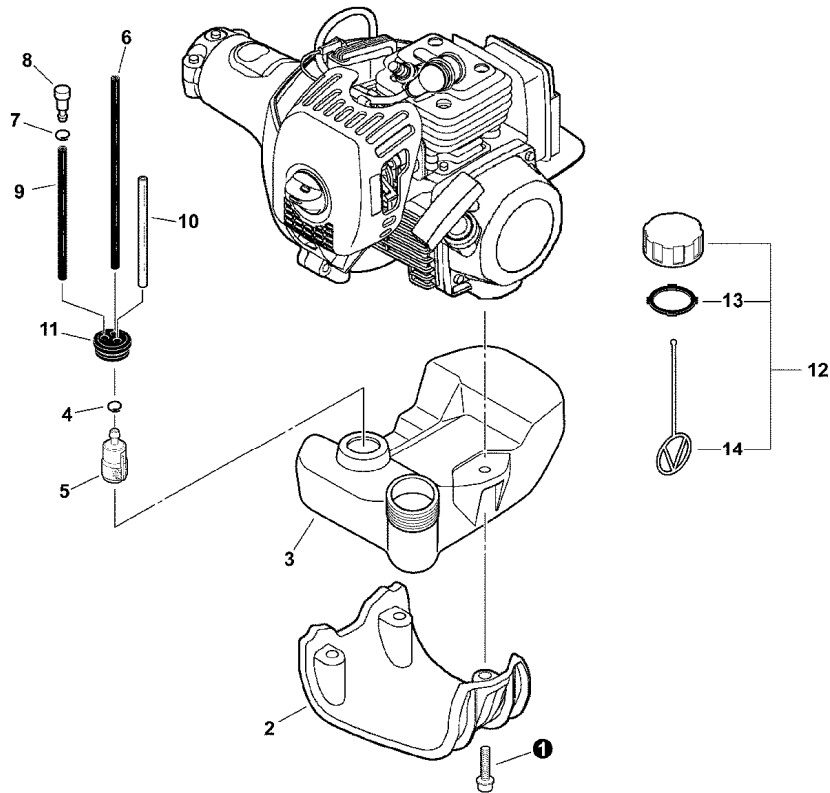

KEY	LV	PART NUMBER	Q'TY	DESCRIPTION	REMARKS	NOTE1	NOTE2
1		900106-05020	3	BOLT, H.S. 5*20	5*20		
2		A175-000040	1	STAND			
3		A350-000900	1	TANK,FUEL			
4		132013-09820	1	CLIP	6MM		
5		A369-000000	1	STRAINER, FUEL	125-528		
6		V470-000580	1	PIPE	3*5*195		
7		132013-26630	1	CLIP	6.5MM		
8		A356-000030	1	VALVE,CHECK			
9		V471-000110	1	PIPE	3*6*115		
10		132012-56030	1	PIPE	3*6*80 YL		
11		132115-55930	1	GROMMET, FUEL			
12		131004-55530	1	CAP ASSY, FUEL TANK			
13	+	131016-55830	1	GASKET, FUEL CAP			
14	+	131051-56030	1	CLIP, FUEL CAP	100L		

### 3. RECOIL STARTER

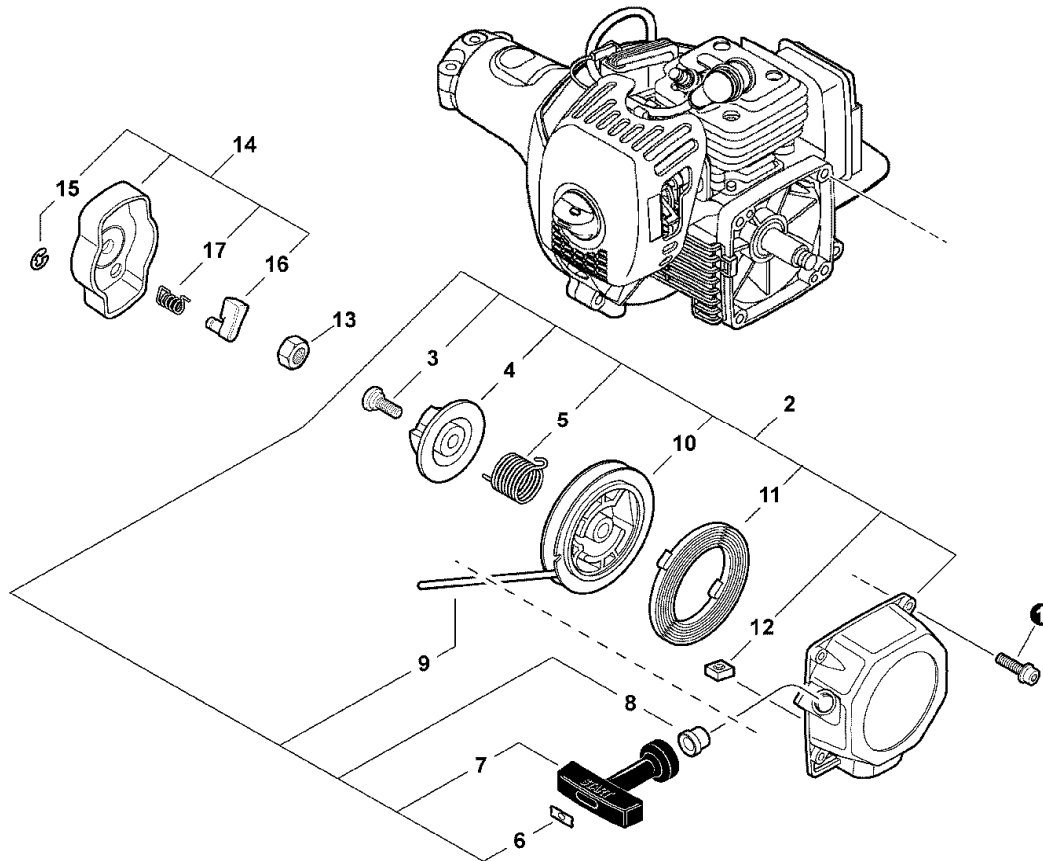

KEY	LV	PART NUMBER	Q'TY	DESCRIPTION	REMARKS	NOTE1	NOTE2
1		V203-000260	4	BOLT,5	FCB5*16		
2		A051-001211	1	STARTER,RECOIL ASY			
3	+	177236-61830	1	SCREW			
4	+	P022-008280	1	PLATE, CAM			
5	+	P022-008270	1	SPRING,DAMPER			
6	+	177246-11120	1	CLIP, STARTER ROPE			
7	+	177228-27030	1	GRIP, STARTER			
8	+	177227-42030	1	GUIDE, ROPE			
9	+	P022-022110	1	ROPE, STARTER			
10	+	A506-000030	1	REEL,ROPE			
11	+	177220-40630	1	SPRING, REWIND			
12	+	900565-00005	1	NUT	5		
13		900502-00008	1	NUT 8 (3N)	3N8		
14		A052-000180	1	PULLEY,ASM STARTER			
15	+	P022-002100	1	E-RING	4		
16	+	P022-006850	1	PAWL, STARTER			
17	+	P022-006510	1	SPRING, RETURN			

## 4. FAN CASE

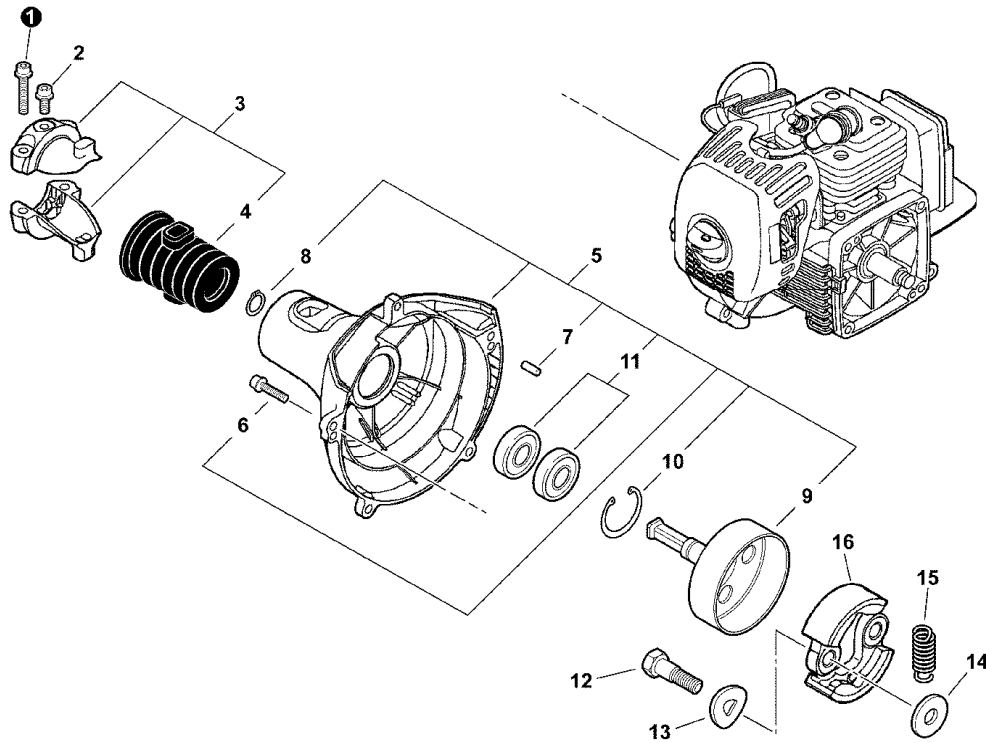

KEY	LV	PART NUMBER	Q'TY	DESCRIPTION	REMARKS	NOTE1	NOTE2
1		900106-05025	2	BOLT, H.S. 5*25	5*25		
2		900106-05010	1	BOLT, H.S. 5*10			
3		P021-013900	1	FIXTURE, MAIN PIPE			
4	+	V420-001400	1	CUSHION			
5		P021-039440	1	COVER ASY, FAN			
6	+	900106-05020	4	BOLT, H.S. 5*20	5*20		
7	+	100215-03930	2	PIN, DOWEL			
8	+	900701-00012	1	CIRCLIP 12	CS-12		
9	+	A556-000600	1	DRUM, CLUTCH	φ64, □6.95		
10	+	900702-00028	1	CIRCLIP 28	CR-28		
11	+	900807-06001	2	BEARING, BALL 6001	6001V(LB)		
12		175046-56030	2	SHAFT, CLUTCH			
13		175049-56030	2	WASHER	8.5*16*0.5		
14		175048-05530	2	WASHER (I)	6.2*19*1.0		
15		A566-000020	1	SPRING, CLUTCH			
16		A553-000050	2	ARM, CLUTCH			

5. AIR CLEANER

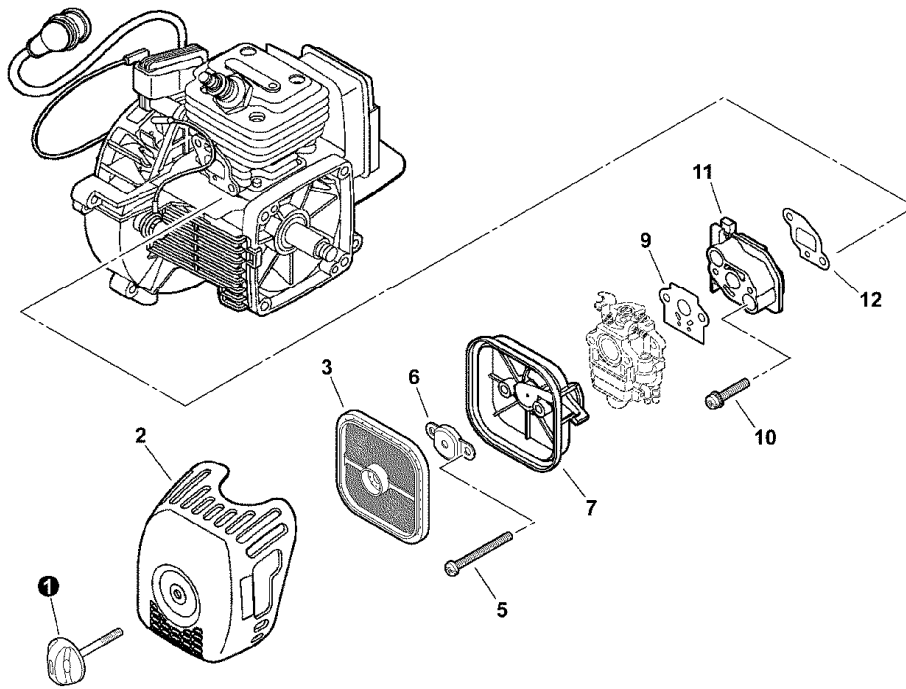

KEY	LV	PART NUMBER	Q'TY	DESCRIPTION	REMARKS	NOTE1	NOTE2
1		V299-000250	1	KNOB,FASTENER			
2		A232-000360	1	LID,CLEANER	ID #1320		
3		A226-000471	1	ELEMENT, AIR FILTER			
5		900242-05060	2	SCREW 5*60	5*60		
6		A244-000070	1	PLATE,PREVENT			
7		P021-013820	1	CASE, AIR CLEANER			
9		V103-000160	1	GASKET,INTAKE			
10		900106-05030	2	BOLT, H.S.H. 5*30	5*30		
11		A200-000270	1	INSULATOR, INTAKE	PM9685L		
12		V103-000380	1	GASKET,INTAKE	T0.5		

6. CARBURETOR

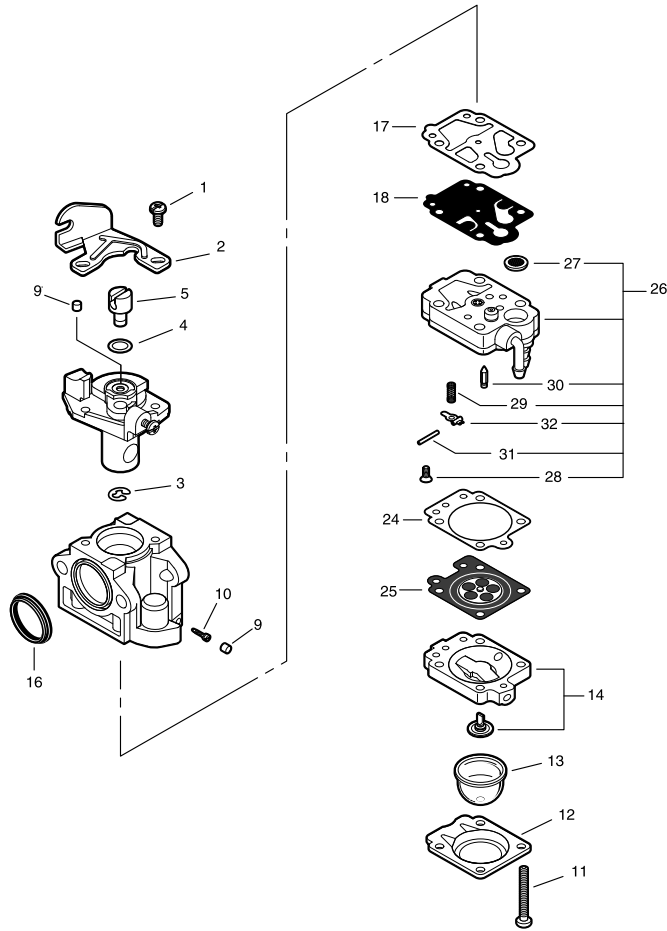

KEY	LV	PART NUMBER	Q'TY	DESCRIPTION	REMARKS	NOTE1	NOTE2
		A021-001340	1	CARBURETOR,DIAPHRAGM	WYK-233A		
1		123114-40630	2	SCREW			
2		P003-000180	1	BRACKET CABLE			
3		123173-07930	1	CLIP			
4		123149-54230	1	WASHER			
5		123172-45130	1	SWIVEL			
9		A259-000000	2	CAP,LIMITER	WALBRO 88-265		
10		P003-001130	1	NEEDLE, HIGH SPEED			
11		123110-05560	4	SCREW, PUMP COVER			
12		123142-05560	1	COVER, PRIMER PUMP			
13		123181-40630	1	PUMP, PRIMER			
14		123180-05560	1	BODY, AIR PURGE			
16		123143-12110	1	RING, PACKING			
17		P003-000100	1	GASKET, PUMP			
18		123112-40630	1	DIAPHRAGM, PUMP			
24		123140-05560	1	GASKET, M. DIAPHRAGM			
25		P003-001850	1	DIAPHRAGM, METERING			
26		P003-000440	1	BODY ASY, PUMP			
27	+	123126-10631	1	SCREEN, INLET			
28	+	123139-05560	1	SCREW, M. LEVER PIN			
29	+	P003-000450	1	SPRING, METER. LEVER			
30	+	123137-19830	1	VALVE, INLET NEEDLE			
31	+	123138-03930	1	PIN, METERING LEVER			
32	+	123123-03930	1	LEVER, METERING			

## 7. MUFFLER

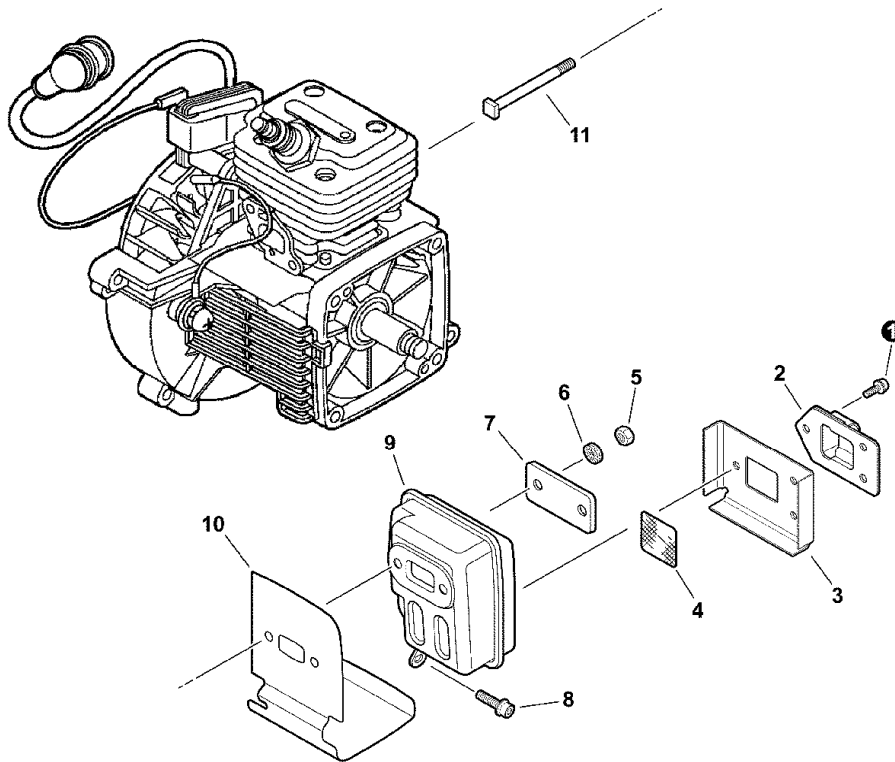

KEY	LV	PART NUMBER	Q'TY	DESCRIPTION	REMARKS	NOTE1	NOTE2
1		91367-04010	3	SCREW	4*10/SW(SUS)		
2		A313-000860	1	GUIDE, EXHAUST			
3		V104-000790	1	GASKET, EXHAUST			
4		145862-40630	1	SCREEN, MUFFLER			
5		900500-00005	2	NUT 5	5		
6		92280-05000	2	WASHER, NORD-LOCK	NL5 5.4*9*1.8		
7		V150-001760	1	PLATE, EYE			
8		900106-05016	1	BOLT, H.S. 5*16	5*16		
9		A300-000640	1	MUFFLER, EXHAUST	CAT25X26DEF STAY		
10		V104-000810	1	GASKET, EXHAUST	NP7002 T:1.0		
11		V203-000120	2	BOLT, 5	L=60		



# 8. MAGNETO

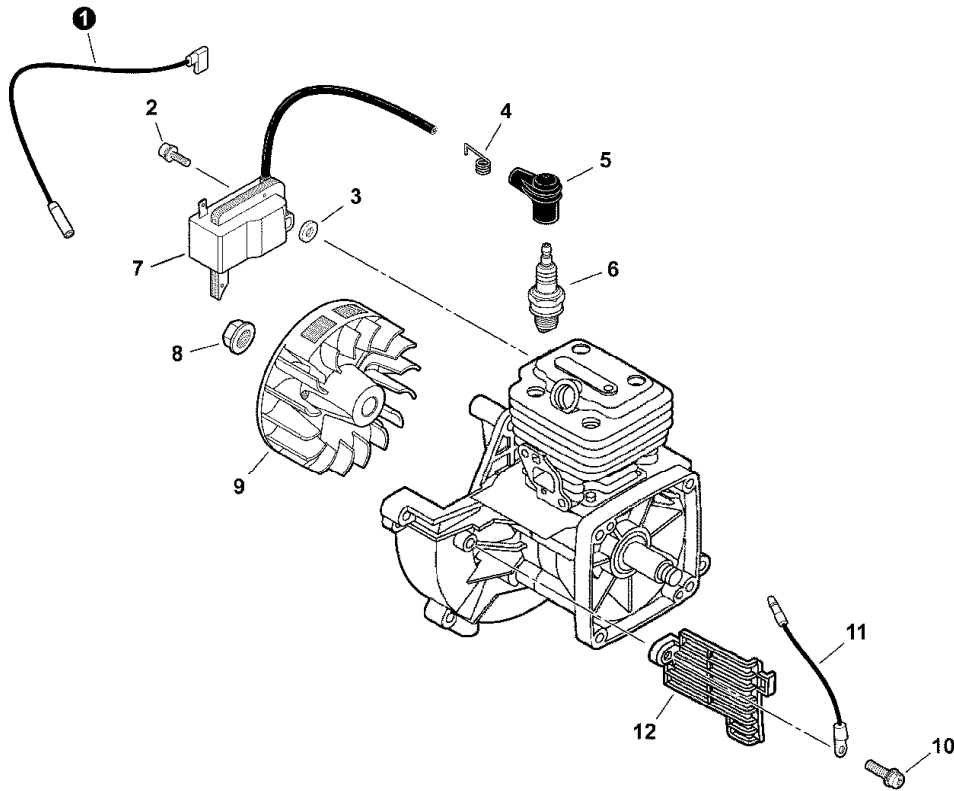

KEY	LV	PART NUMBER	Q'TY	DESCRIPTION	REMARKS	NOTE1	NOTE2
1		V485-000810	1	LEAD	L215		
2		900162-05020	2	BOLT, H.S. 5*20	5*20 W,SW		
3		V323-000070	2	WASHER,CIRCULAR 5	5.2*10*3		
4		159011-03432	1	COIL, SPARK PLUG			
5		159012-03433	1	CAP, SPARK PLUG			
6		A425-000000	1	SPARKPLUG	BPMR8Y		
7		A411-000312	1	COIL, IGNITION	ID#C10415		
8		900515-00008	1	NUT, FLANGE 8	8		
9		A409-000290	1	ROTOR, MAGNETO			
10		900242-05010	1	SCREW 5*10			
11		162014-27230	1	LEAD, GROUND			
12		A127-000150	1	COVER,DUST			

## 9. CYLINDER, CRANKCASE, PISTON

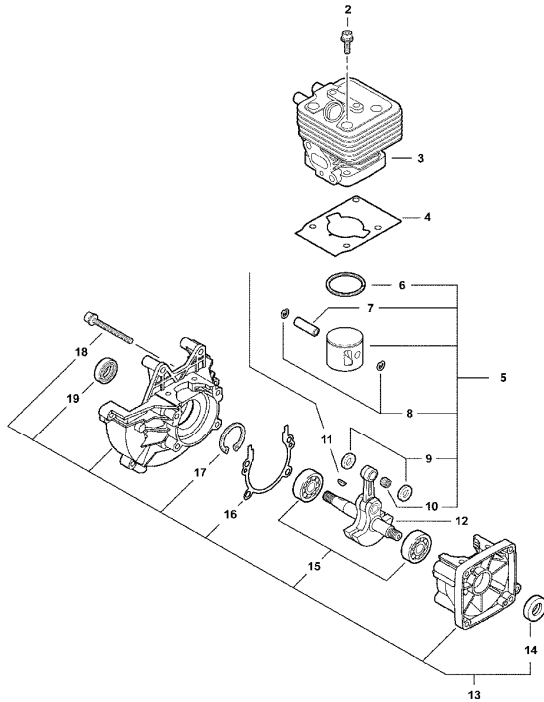

KEY	LV	PART NUMBER	Q'TY	DESCRIPTION	REMARKS	NOTE1	NOTE2
2		91128-05025	4	BOLT HSH			
3		A130-000800	1	CYLINDER			
4		V100-000201	1	GASKET,CYL			
5		P021-010730	1	PISTON KIT			
6	+	A101-000170	1	RING, PISTON	34*1.5*1.5		
7	+	100013-35430	1	PIN, PISTON	6*9*27.8		
8	+	100015-03931	2	CIRCLIP, PISTON PIN			
9	+	V306-000200	2	WASHER,CIRCULAR 8	9.2*14*T0.5		
10	+	100012-16131	1	BEARING, NEEDLE			
11		100142-12330	1	KEY, WOODRUFF			
12		A011-000471	1	CRANKSHAFT,ASY			
13		P021-010741	1	CRANKCASE KIT			
14	+	V505-000020	1	SEAL,OIL 12	12*22*7		
15	+	94035-36201	1	BEARING BALL	6201X3JR2C3		
16	+	V102-000030	1	GASKET,CRANKCASE	T:0.5		
17	+	900702-00032	1	CIRCLIP 32	CR-32		
18	+	91128-05028	4	BOLT HSH			
19	+	100212-03930	1	OILSEAL	ISCX12*32*5.5		

## 10. GEAR CASE

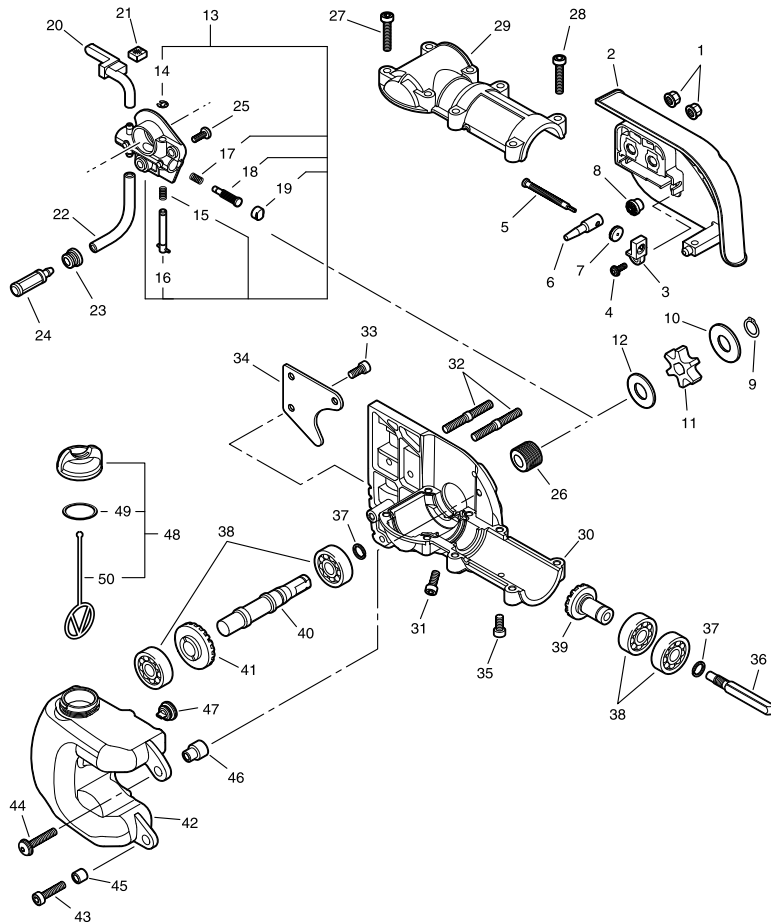

KEY	LV	PART NUMBER	Q'TY	DESCRIPTION	REMARKS	NOTE1	NOTE2
1		433019-03933	2	NUT, FLANGE 6	6		
2		C300-000920	1	GUARD, SPROCKET	COVER W/SCREW		
3		V355-000140	1	COLLAR,8			
4		V252-000040	1	SCREW,4	4*8 PT SCREW		
5		V203-000041	1	BOLT,5			
6		C309-000030	1	TENSIONER,CHAIN			
7		V651-000310	1	GEAR,BEVEL	14 TEETH 3.0 SQ.		
8		V651-000320	1	GEAR,BEVEL	14 TEETH 10MM LG		
9		V583-000090	1	RING	EXTERNAL RING		
10		V307-000160	1	WASHER,CIRCULAR 10	10.2*29.5*T=1.2		
11		C580-000070	1	SPROCKET,DRIVE			
12		175014-39131	1	WASHER, CLUTCH	10.2*24.5*1.2		
13		C022-000010	1	OILER,ASM AUTO			
14	+	125327-15130	1	CLIP			
15	+	P022-010670	1	SPRING			
16	+	P022-010680	1	SCREW ASS'Y, ADJUST			
17	+	P022-010660	1	SPRING			
18	+	P022-010650	1	PLUNGER			
19	+	P022-010640	1	CAP, OIL PUMP			
20		V470-000180	1	PIPE			

## 10. GEAR CASE

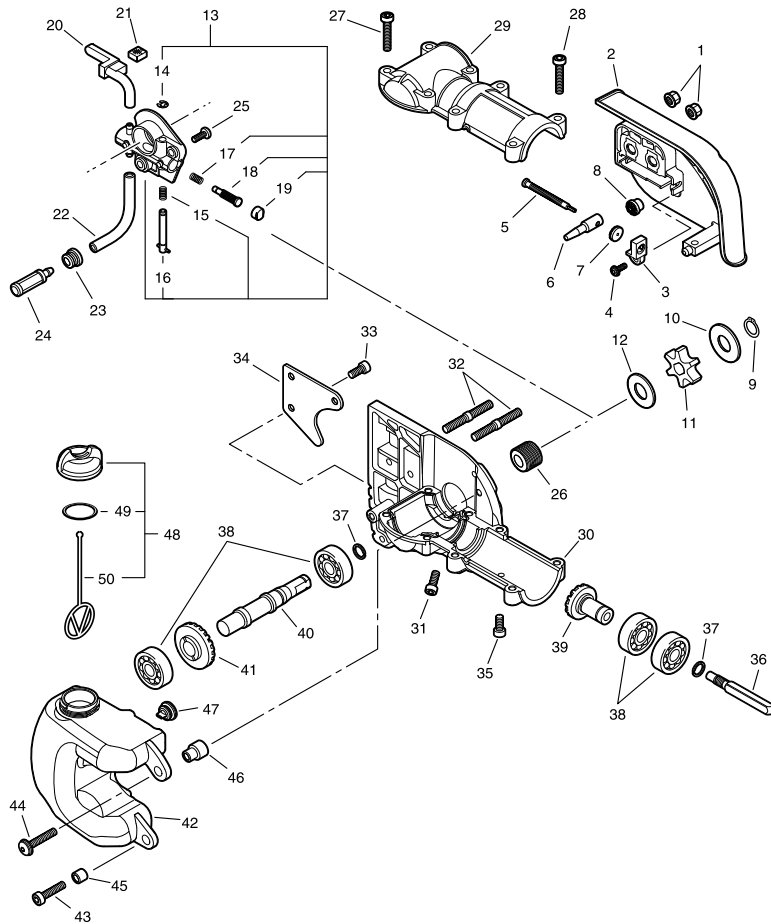

KEY	LV	PART NUMBER	Q'TY	DESCRIPTION	REMARKS	NOTE1	NOTE2
21		437244-39130	1	PAD, FORM			
22		130110-12330	1	PIPE, IMPULSE	3*6*70L		
23		132115-01461	1	GROMMET			
24		436205-02832	1	STRAINER, OIL			
25		V253-000200	2	SCREW,5	M5*10 PAN MS		
26		437063-38330	1	GEAR, WORM			
27		900105-05025	4	BOLT, H.S. 5*25	5*25		
28		V253-000240	4	SCREW,5	M5*25 PAN MS		
29		C531-000030	1	CASE, GEAR			
30		C531-000430	1	CASE, GEAR	LOWER		
31		V253-000200	1	SCREW,5	M5*10 PAN MS		
32		V224-000040	2	BOLT, STUD 6	15MM*19MM M6		
33		V253-000200	3	SCREW,5	M5*10 PAN MS		
34		C649-000140	1	HOOK	BRANCH HOOK		
35		900105-05010	1	BOLT, H.S. 5*10	5*10		
36		610025-22361	1	CONNECTOR, SHAFT			
37		900706-00012	2	CIRCLIP 12	WR-12		
38		94052-06001	4	BEARING BALL	PEER LLU,DDU 2RS		
39	+	V651-000201	1	GEAR, BEVEL	MG 0600.2259		
40		C534-000430	1	SHAFT, GEAR			
41		V651-000210	1	GEAR, BEVEL	MG 0600.2259		
42		C200-000080	1	TANK, OIL			
43		V253-000240	1	SCREW,5	M5*25 PAN MS		
44		V253-000230	2	SCREW,5	M5*20 PAN MS		
45		131045-28230	2	COLLAR			

# 10. GEAR CASE

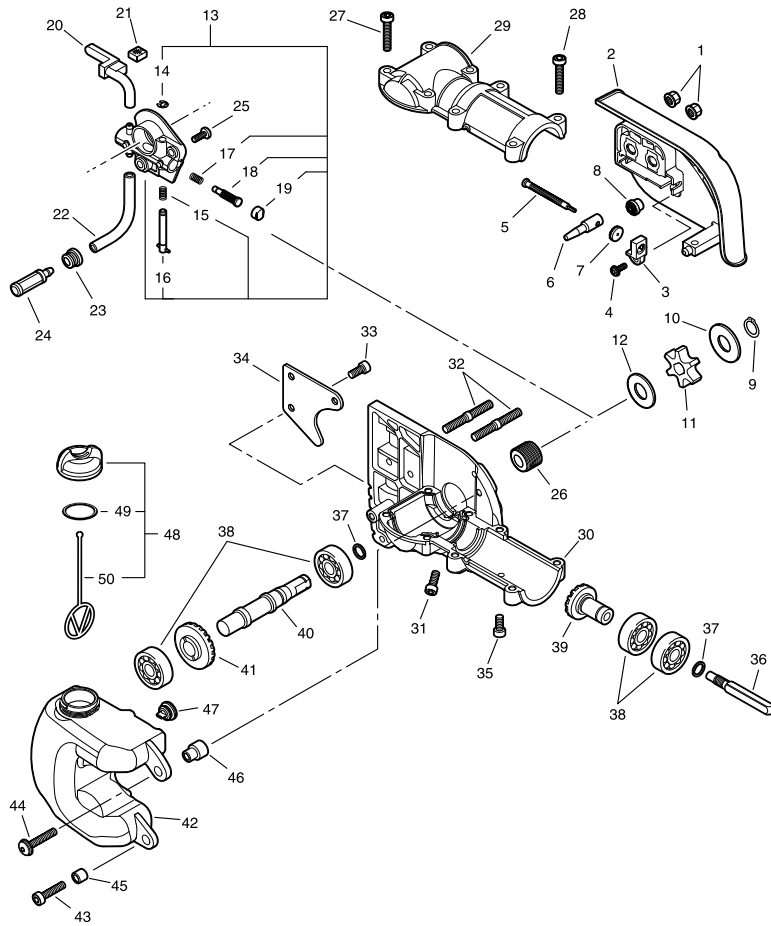

KEY	LV	PART NUMBER	Q'TY	DESCRIPTION	REMARKS	NOTE1	NOTE2
46		V354-000010	1	COLLAR,6			
47		131314-06320	1	VALVE, CHECK			
48		P021-005591	1	CAP ASY			
49	+	900720-00018	1	O-RING 18	P-18		
50	+	A365-000050	1	CONNECTOR,CAP			

11. ACCESSORIES

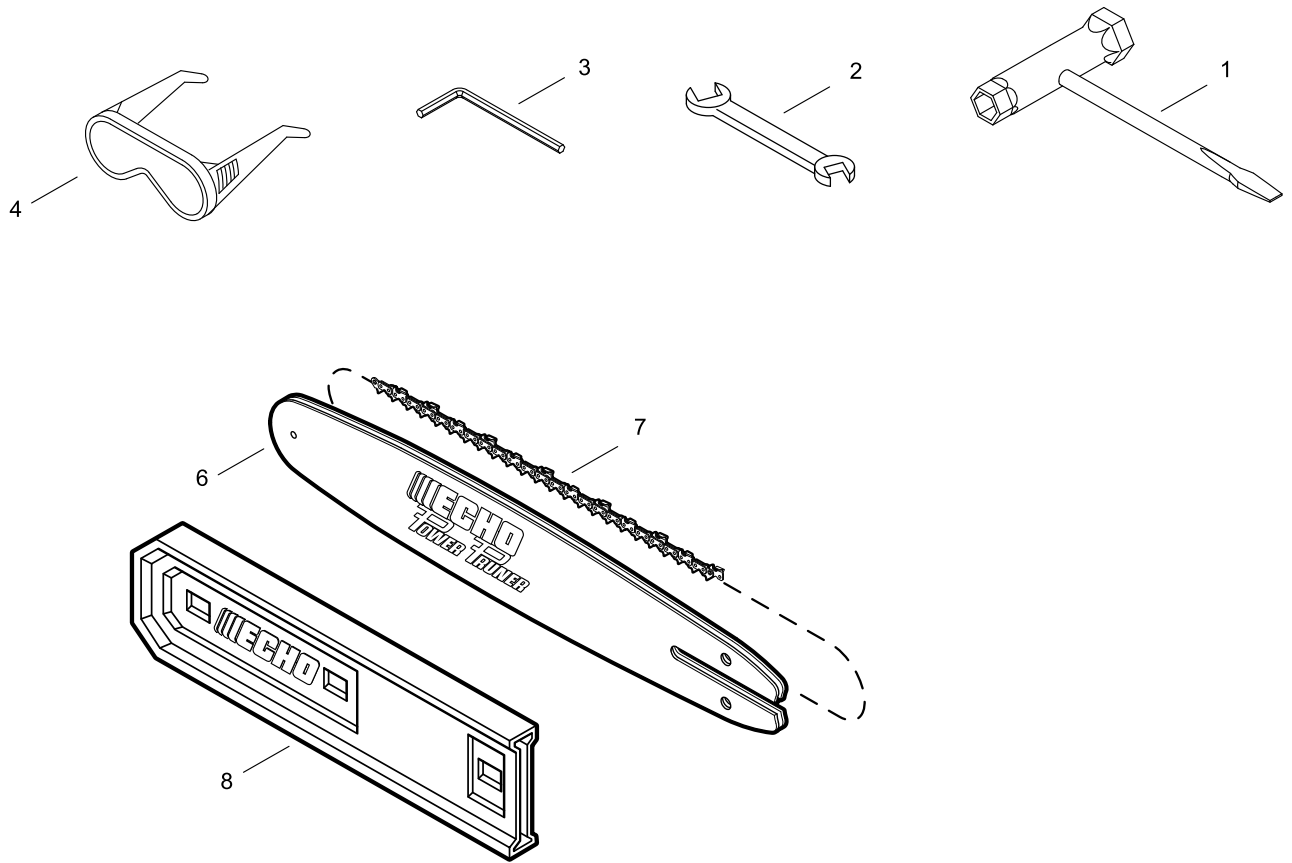

KEY	LV	PART NUMBER	Q'TY	DESCRIPTION	REMARKS	NOTE1	NOTE2
1		895410-39131	1	WRENCH, W/S-DRIVER			
2		895112-00330	1	SPANNER 8*10			
3		X605-000100	1	TOOL,L WRENCH	4MM M5㉿		
4		X690-000050	1	GOGGLE	GOGGLE + NOTE		
6		X122-000150	1	BAR,GUIDE 30	12A0CD3744		
7		431611-22461	1	CHAIN,SAW	91VX44CQ		
8		X490-000050	1	SCABBARD,CHAIN	12" BAR		

## 12. DRIVE SHAFT

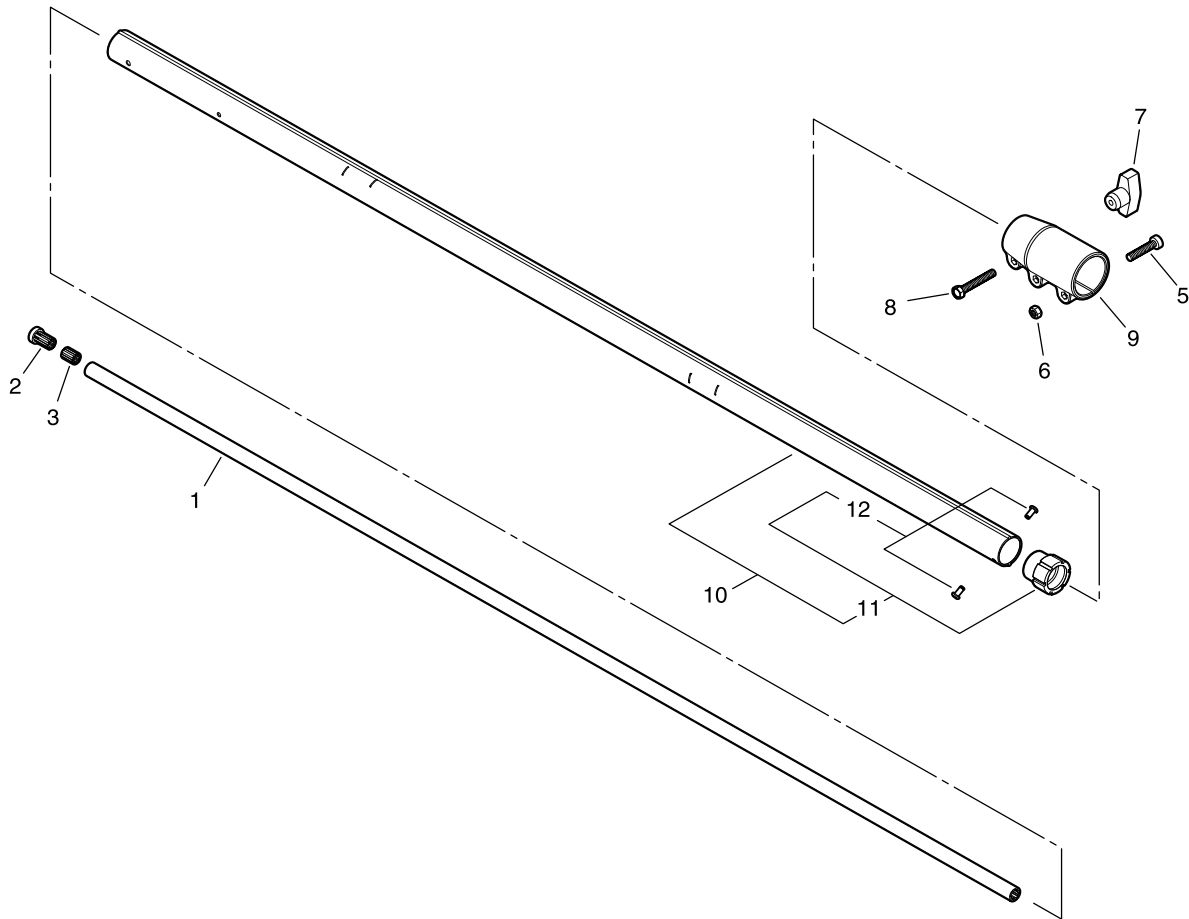

KEY	LV	PART NUMBER	Q'TY	DESCRIPTION	REMARKS	NOTE1	NOTE2
1		C504-000410	1	SHAFT, DRIVE	L:65.875 IN.		
2		C509-000080	1	SOCKET, SHAFT	12.2*16.5*25.4		
3		C509-000090	1	SOCKET, SHAFT	DRIVE SIDE		
5		900105-05020	2	BOLT, H.S. 5*20	5*20		
6		900500-00005	2	NUT 5	5		
7		V299-000321	1	KNOB, FASTENER	M6X1.0 THREAD		
8		900100-06025	1	BOLT 6*25	6*25		
9		C510-000171	1	COUPLING, MAIN PIPE	UPPER COUPLING		
10		C050-001030	1	PIPE, MAIN	PIPE ASS'Y		
11	++	C503-000080	1	HOLDER, BEARING	HOLDER ASSEMBLY		
12	++	890011-22360	2	RIVET			

13. DRIVE SHAFT

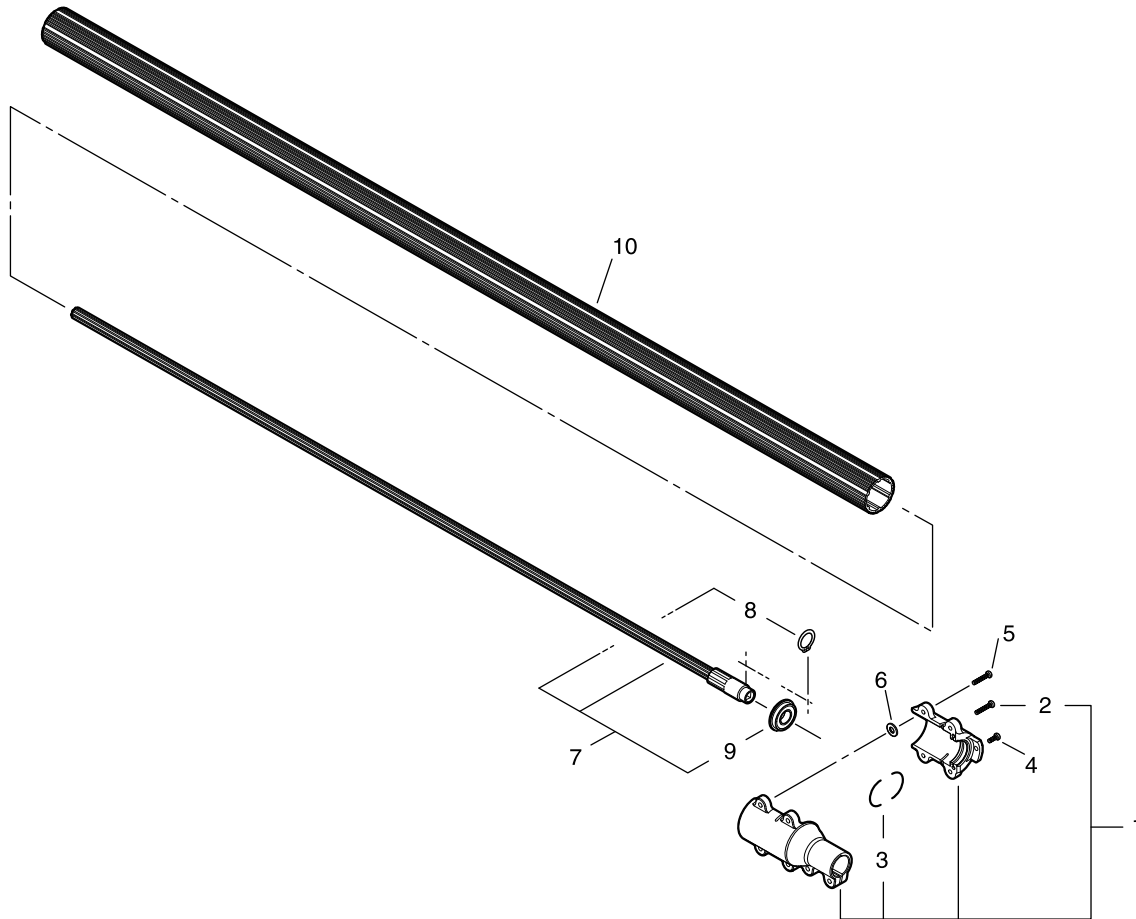

KEY	LV	PART NUMBER	Q'TY	DESCRIPTION	REMARKS	NOTE1	NOTE2
1		C510-000163	1	COUPLING, MAIN PIPE	MACHINED 2-PARTS		
2	+	900105-05020	2	BOLT, H.S. 5*20	5*20		
3	+	V420-001810	2	CUSHION	OD 3.53MM*42 LNG		
4		900105-05014	1	BOLT, H.S. 5*14	5*14		
5		900105-05020	4	BOLT, H.S. 5*20	5*20		
6		V303-000071	2	WASHER,CIRCULAR 5	5.4MM*15MM*1MM		
7		C504-000440	1	SHAFT, DRIVE	L:1701		
8	+	100229-22460	1	RING			
9	+	94057-36002	1	BEARING, BALL	PEER LLU,DDU		
10		C500-000330	1	PIPE, MAIN			



## 14. THROTTLE LEVER

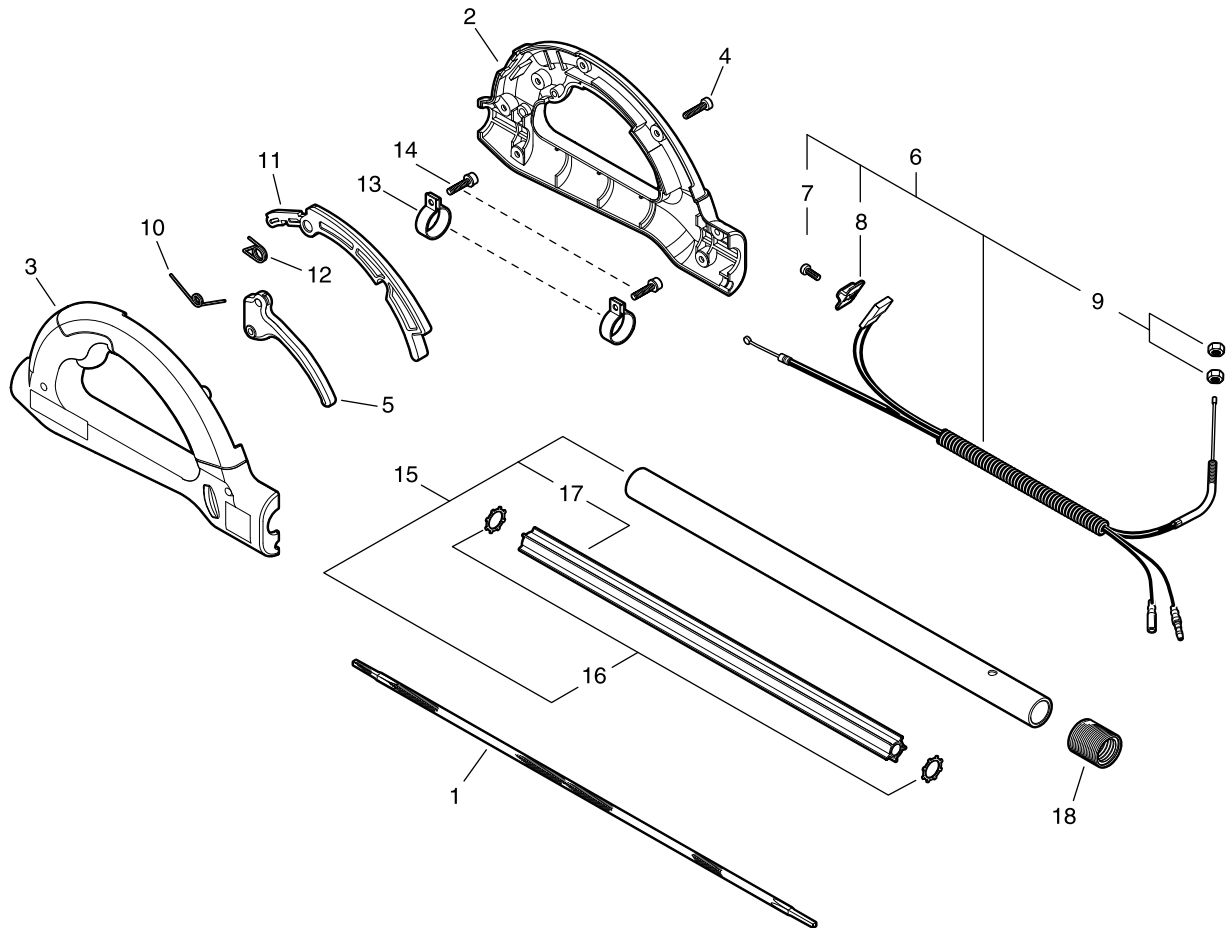

KEY	LV	PART NUMBER	Q'TY	DESCRIPTION	REMARKS	NOTE1	NOTE2
1		C506-000140	1	SHAFT, FLEXIBLE	6.8 BOTH ENDS		
2		C041-000000	1	HANDLE,ASM REAR	OVERMOLD - RIGHT		
3		C041-000011	1	HANDLE,ASM REAR	OVERMOLD - LEFT		
04		V253-000210	7	SCREW,5	M5*18 PAN PT		
5		C450-000260	1	CONTROL, THROTTLE	PPT HANDLE		
6		P021-039450	1	CABLE ASY,CONTROL			
7	+	91545-03010	1	SCREW TAPTITE-P			
8	+	A444-000020	1	KNOB,SWITCH	ACT3020-14F		
9	+	900502-00006	2	NUT 6 (3N)	3N6		
10		V452-000330	1	SPRING,TORSION	30MM*8 DIA.*30MM		
11		C460-000100	1	LOCKOUT, THROTTLE	PPT HANDLE		
12		V452-000340	1	SPRING,TORSION	10.5MM I.D.		
13		V495-000680	2	BAND			
14		V253-000220	2	SCREW,5	M5*20 PAN SEM MS		
15		C050-001040	1	PIPE, MAIN	PIPE ASS'Y (280)		
16	+	V583-000110	2	RING	.625ID * .875OD		
17	+	C507-000160	1	LINER, FLEXIBLE	L=410MM		
18		V475-004000	1	TUBE	25MM*32MM*35M		

15. LABEL

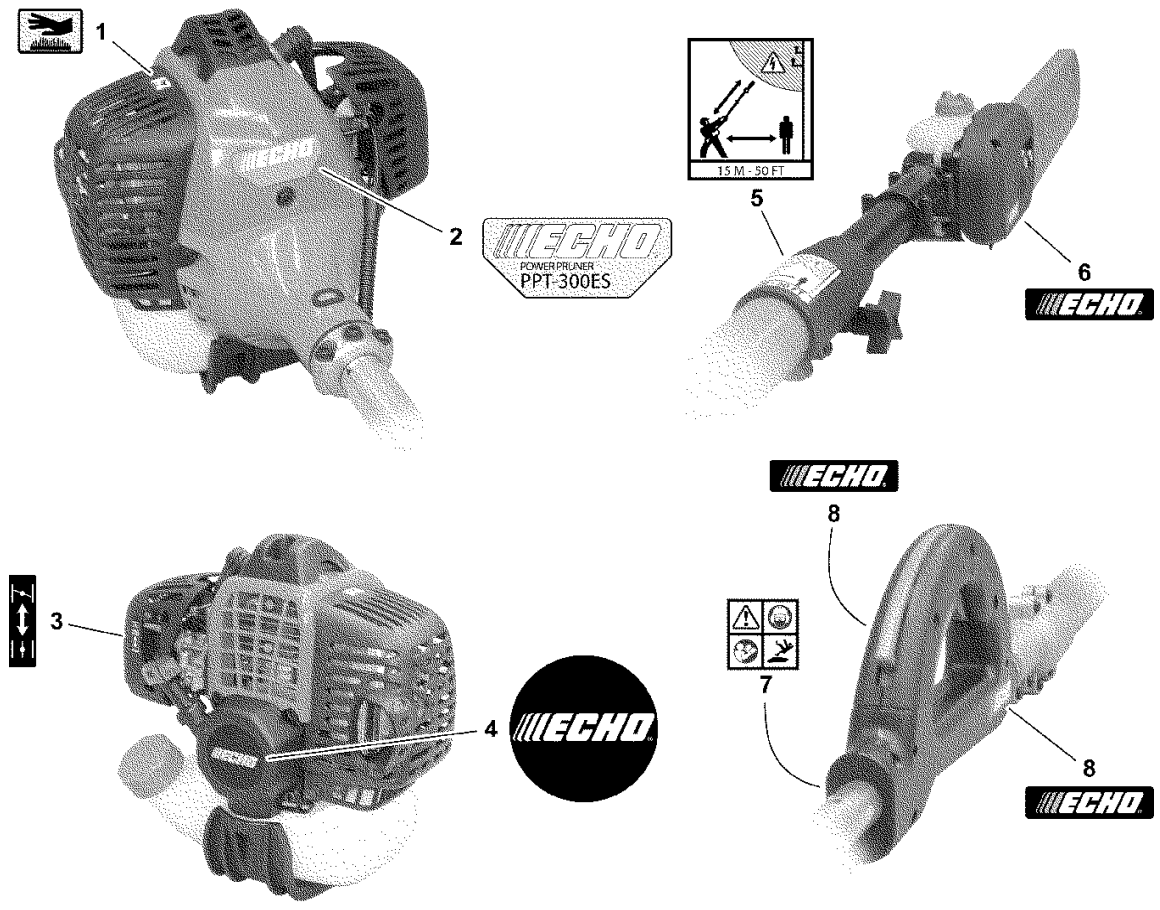

KEY	LV	PART NUMBER	Q'TY	DESCRIPTION	REMARKS	NOTE1	NOTE2
1		X505-002310	1	LABEL,CAUTION	HOT CAUTION		
2		X547-001880	1	LABEL,ECHO	ECHO+PPT-300ES		
3		890332-52730	1	LABEL, CHOKE			
4		X502-000330	1	LABEL,ECHO	ECHO		
5		X505-002371	1	LABEL,CAUTION	15M-50FT PRUNER		
6		X502-000600	1	LABEL,ECHO	48MM*15MM + ECHO		
7		X505-002361	1	LABEL,CAUTION	4-ISO SYMBOLS		
8		X502-000610	2	LABEL,ECHO	62MM*16MM + ECHO		

16. HARNESS

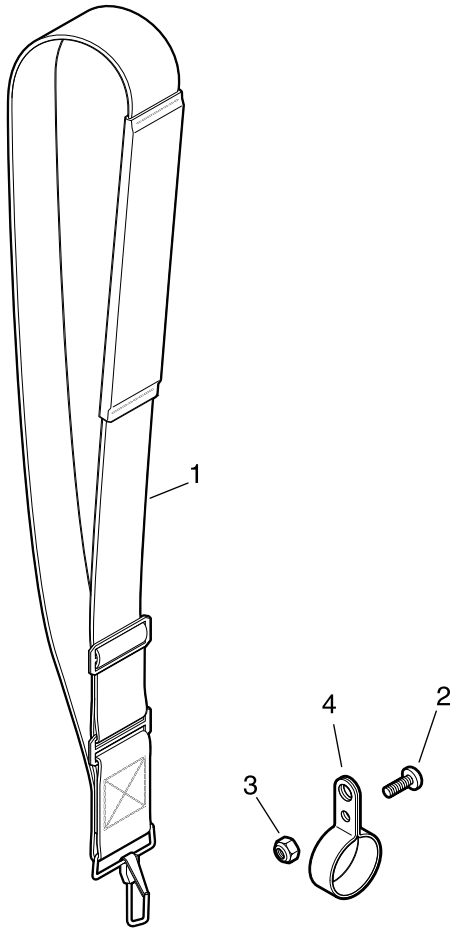

KEY	LV	PART NUMBER	Q'TY	DESCRIPTION	REMARKS	NOTE1	NOTE2
1		301000-22060	1	HARNESS ASY, SHOULDER			
2		V253-000200	1	SCREW, 5	M5*10 PAN MS		
3		V263-000080	1	NUT, 5	M5*0.8 LOCK NUT		
4		300610-22061	1	BRACKET, HARNESS	24.69/24.84 I.D.		

**Index**

<b>Patrs Number</b>	<b>Key No.</b>	<b>Patrs Number</b>	<b>Key No.</b>	<b>Patrs Number</b>	<b>Key No.</b>
100012-16131	9 - 10	301000-22060	16 - 1	A011-000471	9 - 12
100013-35430	9 - 7	431611-22461	11 - 7	A021-001340	6 -
100015-03931	9 - 8	433019-03933	10 - 1	A051-001211	3 - 2
100142-12330	9 - 11	436205-02832	10 - 24	A052-000180	3 - 14
100212-03930	9 - 19	437063-38330	10 - 26	A101-000170	9 - 6
100215-03930	4 - 7	437244-39130	10 - 21	A127-000150	8 - 12
100229-22460	13 - 8	610025-22361	10 - 36	A130-000800	9 - 3
123110-05560	6 - 11	890011-22360	12 - 12	A160-000800	1 - 7
123112-40630	6 - 18	890332-52730	15 - 3	A162-000110	1 - 5
123114-40630	6 - 1	895112-00330	11 - 2	A175-000040	2 - 2
123123-03930	6 - 32	895410-39131	11 - 1	A200-000270	5 - 11
123126-10631	6 - 27	900100-06025	12 - 8	A226-000471	5 - 3
123137-19830	6 - 30	900105-05010	10 - 35	A232-000360	5 - 2
123138-03930	6 - 31	900105-05014	13 - 4	A244-000070	5 - 6
123139-05560	6 - 28	900105-05020	12 - 5	A259-000000	6 - 9
123140-05560	6 - 24	900105-05020	13 - 2	A300-000640	7 - 9
123142-05560	6 - 12	900105-05020	13 - 5	A313-000860	7 - 2
123143-12110	6 - 16	900105-05025	10 - 27	A320-000400	1 - 3
123149-54230	6 - 4	900106-05010	1 - 6	A350-000900	2 - 3
123172-45130	6 - 5	900106-05010	4 - 2	A356-000030	2 - 8
123173-07930	6 - 3	900106-05016	7 - 8	A365-000050	10 - 50
123180-05560	6 - 14	900106-05020	1 - 2	A369-000000	2 - 5
123181-40630	6 - 13	900106-05020	2 - 1	A409-000290	8 - 9
125327-15130	10 - 14	900106-05020	4 - 6	A411-000312	8 - 7
130110-12330	10 - 22	900106-05025	4 - 1	A425-000000	8 - 6
131004-55530	2 - 12	900106-05030	5 - 10	A444-000020	14 - 8
131016-55830	2 - 13	900162-05020	8 - 2	A506-000030	3 - 10
131045-28230	10 - 45	900242-05010	8 - 10	A553-000050	4 - 16
131051-56030	2 - 14	900242-05060	5 - 5	A556-000600	4 - 9
131314-06320	10 - 47	900500-00005	7 - 5	A566-000020	4 - 15
132012-56030	2 - 10	900500-00005	12 - 6	C022-000010	10 - 13
132013-09820	2 - 4	900502-00006	14 - 9	C041-000000	14 - 2
132013-26630	2 - 7	900502-00008	3 - 13	C041-000011	14 - 3
132115-01461	10 - 23	900515-00008	8 - 8	C050-001030	12 - 10
132115-55930	2 - 11	900565-00005	3 - 12	C050-001040	14 - 15
145862-40630	7 - 4	900701-00012	4 - 8	C200-000080	10 - 42
159011-03432	8 - 4	900702-00028	4 - 10	C300-000920	10 - 2
159012-03433	8 - 5	900702-00032	9 - 17	C309-000030	10 - 6
162014-27230	8 - 11	900706-00012	10 - 37	C450-000260	14 - 5
175014-39131	10 - 12	900720-00018	10 - 49	C460-000100	14 - 11
175046-56030	4 - 12	900807-06001	4 - 11	C500-000330	13 - 10
175048-05530	4 - 14	91128-05025	9 - 2	C503-000080	12 - 11
175049-56030	4 - 13	91128-05028	9 - 18	C504-000410	12 - 1
177220-40630	3 - 11	91367-04010	7 - 1	C504-000440	13 - 7
177227-42030	3 - 8	91545-03010	14 - 7	C506-000140	14 - 1
177228-27030	3 - 7	92280-05000	7 - 6	C507-000160	14 - 17
177236-61830	3 - 3	94035-36201	9 - 15	C509-000080	12 - 2
177246-11120	3 - 6	94052-06001	10 - 38	C509-000090	12 - 3
300610-22061	16 - 4	94057-36002	13 - 9	C510-000163	13 - 1

**Index**

<b>Patrs Number</b>	<b>Key No.</b>	<b>Patrs Number</b>	<b>Key No.</b>	<b>Patrs Number</b>	<b>Key No.</b>
C510-000171	12 - 9	V253-000220	14 - 14		
C531-000030	10 - 29	V253-000230	10 - 44		
C531-000430	10 - 30	V253-000240	10 - 28		
C534-000430	10 - 40	V253-000240	10 - 43		
C580-000070	10 - 11	V263-000080	16 - 3		
C649-000140	10 - 34	V299-000250	5 - 1		
P003-000100	6 - 17	V299-000321	12 - 7		
P003-000180	6 - 2	V303-000071	13 - 6		
P003-000440	6 - 26	V306-000200	9 - 9		
P003-000450	6 - 29	V307-000160	10 - 10		
P003-001130	6 - 10	V323-000070	8 - 3		
P003-001850	6 - 25	V354-000010	10 - 46		
P021-005591	10 - 48	V355-000140	10 - 3		
P021-010730	9 - 5	V420-001400	4 - 4		
P021-010741	9 - 13	V420-001810	13 - 3		
P021-013820	5 - 7	V452-000330	14 - 10		
P021-013900	4 - 3	V452-000340	14 - 12		
P021-039440	4 - 5	V470-000180	10 - 20		
P021-039450	14 - 6	V470-000580	2 - 6		
P022-002100	3 - 15	V471-000110	2 - 9		
P022-006510	3 - 17	V475-004000	14 - 18		
P022-006850	3 - 16	V485-000810	8 - 1		
P022-008270	3 - 5	V495-000680	14 - 13		
P022-008280	3 - 4	V505-000020	9 - 14		
P022-010640	10 - 19	V583-000090	10 - 9		
P022-010650	10 - 18	V583-000110	14 - 16		
P022-010660	10 - 17	V651-000201	10 - 39		
P022-010670	10 - 15	V651-000210	10 - 41		
P022-010680	10 - 16	V651-000310	10 - 7		
P022-022110	3 - 9	V651-000320	10 - 8		
V100-000201	9 - 4	X122-000150	11 - 6		
V102-000030	9 - 16	X490-000050	11 - 8		
V103-000160	5 - 9	X502-000330	15 - 4		
V103-000380	5 - 12	X502-000600	15 - 6		
V104-000790	7 - 3	X502-000610	15 - 8		
V104-000810	7 - 10	X505-002310	15 - 1		
V150-001760	7 - 7	X505-002361	15 - 7		
V203-000041	10 - 5	X505-002371	15 - 5		
V203-000120	7 - 11	X547-001880	15 - 2		
V203-000260	1 - 1	X605-000100	11 - 3		
V203-000260	3 - 1	X690-000050	11 - 4		
V203-000270	1 - 4				
V224-000040	10 - 32				
V252-000040	10 - 4				
V253-000200	10 - 25				
V253-000200	10 - 31				
V253-000200	10 - 33				
V253-000200	16 - 2				
V253-000210	14 - 04				

# YAMABIKO CORPORATION

7-2 SUEHIROCHO 1-CHOME, OHME, TOKYO 198-8760, JAPAN  
PHONE: 81-428-32-6118. FAX: 81-428-32-6145.



11Kb  
No. 38-038